

FCA 140

Automatic Double-Clipper



innovative · reliable · leading

poly-clip[®]
SYSTEM

FCA 140

- For the 38-150 mm calibre range at up to 156 cycles per minute in continuous mode
- Shortest down-time for re-loading of casing and maintenance, with even higher safety
- Fully hygienic conveyor belt, dismantling without tools
- Optimal accessibility for ease of cleaning

Applications

Flexibility and product versatility in the mid-size calibre range at up to 156 cycles per minute as well as shortest downtimes distinguish the FCA 140. The automatic double-clipper closes collagen casings up to 58 mm, fibrous casings up to 90 mm and plastic casings up to 150 mm in diameter. The FCA 140 R-ID processes the clip series M and L, the version R-Clip the spacings 15 and 18.

Advantages

- Shortest setup time due to semi-automatic operating concept comprising comfort opening of front flap and optional casing brake assistant; minimizes hand grips when re-loading casing
- Safety casing brake with hand guard; maintaining safety distance to separator when adjusted, operation without casing brake is blocked
- Fully hygienic conveyor belt, dismantling without tools, single lane 700 or 1200 mm, double-belt 700 mm and roller extension
- Highest productivity; product parameters can be recalled from the SAFETY TOUCH recipe management
- Short sausage ends, uniform pleating and clean sausage tails due to the powerful linear voiding separator



- Highly dynamic, energy-efficient servo drive, infinitely adjustable speed via SAFETY TOUCH
- Simple machine operation with SAFETY TOUCH – shockproof, 10" large and easy to clean
- Operator-friendly with individually assignable manual functions, e.g. inching mode
- Tool free quick-change system of the punch
- Comfortable external adjustment of the clip pressure and separator hole, without tools
- Electronic hand-wheel for adjustments and setting parameters
- Low noise level
- Robustness and long service life guaranteed by use of stainless steel and titanium
- Easy to clean due to smooth surfaces, large openings, front flap and the special separator cleaning position
- Maintenance- and service-friendly with few wearing parts, easily accessible by swing-off side covers
- Centralized lubrication strip for easy and fast maintenance
- Swivel horn, twin turret and casing brake assistant with 90° pivot point

- Processes high-quality clips – certified safe for use with food by SGS INSTITUT FRESENIUS
- Clip and loop manufacture certified in accordance with ISO 22000:2005, which incorporates HACCP requirements

FCA 140 R-ID additionally:

- R-ID Clip with high holding force, even up to bacteria-proof clip closure with plastic casings
- Incorrect settings are avoided by detection of the clip size and die
- Highly repeatable, reliable production with sensors monitoring clip pressure and size of separator hole as well as end of clip supply on the reel
- Quick change system for punch and die without tools

Shortest setup time due to comfort opening of front flap



Optional equipment

- Central lubrication, machine cycle-dependent, for maximum reliability and service life
- Intelligent Filler Clipper (IFC) Interface upon request
- Automatic looper GSA 20, loop left or right
- Casing brake assistant – semi-automatic casing brake holder system for fastest reloading of casings
- Pneumatic dry sausage brake, individual control of the twin turret's casing brakes as product parameter via SAFETY TOUCH
- Sensors monitoring size of clip pressure and separator hole (for R-Clip version only)
- Auto-Stop System clip – sensor monitoring the end of clip supply on the reel
- Casing end sensor
- Sensor for end of loop supply
- Air-free slack filling of moulded products by overspreading, sensor monitored total spreading up to 100 mm, comfort setting in front
- Twin-turret with swivel horns
- Length portioning by optical sensor or mechanical length stop up to 1.600 mm
- Clip coding
- Ball joint filler connection
- String dispenser for rings
- Single clip feature with 30 mm spreading
- Print mark control



Function and operation

The FCA 140 Automatic Double-Clipper is connected mechanically and synchronized electrically to a filling machine. The portions are fed in precisely to the nearest gram and closed by a clip. The operator is intuitively guided through the flat menu structure of the SAFETY TOUCH by means of self-explaining pictograms. Operator, set-up and service levels are kept clearly separated and are password protected. A high degree of process monitoring is offered by the FCA's automation. In case of deviations from the recipe parameters saved in SAFETY TOUCH of the FCA 140 R-ID a warning is automatically displayed. The PC control allows a very fast and accurate signal processing. On the SAFETY TOUCH display the diagnostic

system provides a direct and clear indication of the machine's operational status as well an analysis of filling and clipping times. A USB port for data import and export comes as standard. Automation and operating comfort guarantee shortest possible set-up times, even higher operational safety and the maximum efficient machine use within the FCA class.

Combinability

ES 5000 – labelling system for marking and traceability

Casing brake assistant – semi-automatic casing brake holder system



Fully hygienic conveyor belt, dismantling without tools



Easy machine control with the SAFETY TOUCH



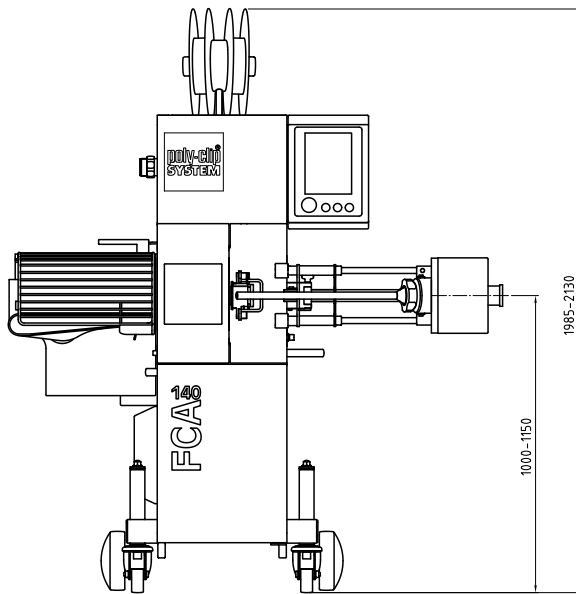

Front view

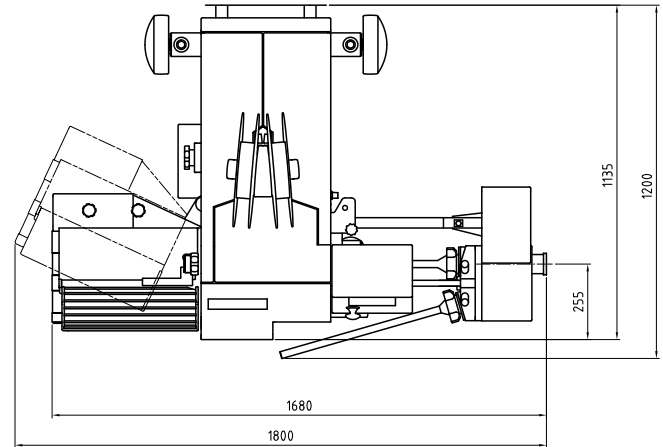

Length of stuffing horn 600

Top view

Width:	1,680-1,800 mm
Depth:	1,200 mm
Height:	1,985-2,130 mm
Weight:	ca. 550 kg
Three-phase current connection:	200-230 VAC, 380-460 VAC, 50/60 Hz
Power input:	4 kW
Fuse connection:	16 A
Compressed air:	5-7 bar/0.5-0.7 MPa
Air consumption:	2.5 NL/cycle

R-ID Clip:	M, L
R-Clip:	15, 18
Spreading:	26, 30, 36 mm
Total spreading up to:	100 mm